

## SPACE SAVING APPLICATIONS

- This system is mainly aimed at side opening cabinets up to 2 metre high.
- A special tracking system enables to save space on the sides of the cabinet.
- Accessories can complement the system : various types of locks and handles.
- Standard colours are offered to suit every customer's requirements : plain, woodgrain, aluminium finishes.

Our shutters have been developed over many years to give easy and quiet operation whilst maintaining optimum rigidity with efficient weight per metre.

### SHUTTER / TRACKING SYSTEM

| reference                  | description  |
|----------------------------|--|
| Shutter profile <b>867</b> | smooth double slat<br>3 X 20 mm  |
| Tracking <b>2323/2324</b>  | T shape clip in track<br>Width 51 mm X length 440 mm / front length 496 mm or 594,5 mm |

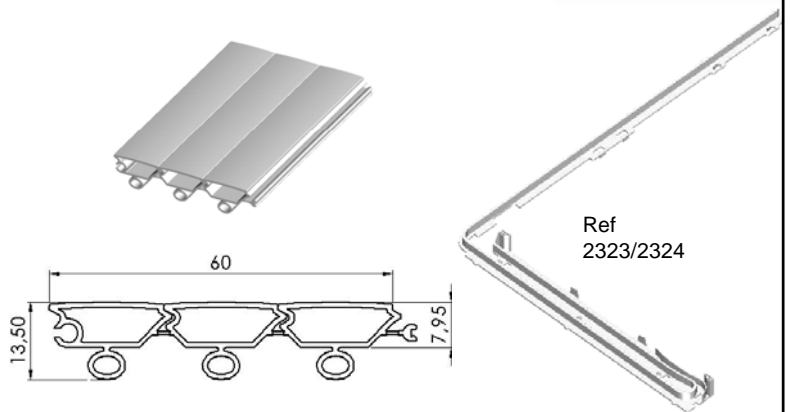

### TERMINAL SLAM

#### Steel terminal + cover slat (With or without magnet) ref 868/869

Our terminal can be supplied fully assembled ready to fit straight in your cabinet reducing your production time

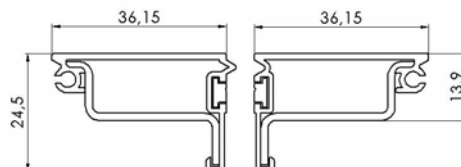

### ACCESSORIES

**Magnet** : recommended to give positive operation on closing

**Handles** : recessed or surface mounted  
Please contact us for specific requirements. Cover slat can be punched to specific shape and size requirements.

**Locks** : 1 point, 2 point, multi point

**Track** : see our leaflet to find the most suitable tracking system for your cabinet.

